

Light efficiency:



Light quality:



Color temperature:



Output: 1065 lm

Peak: 276 cd

Power: 8,0 W

PF: 0,55

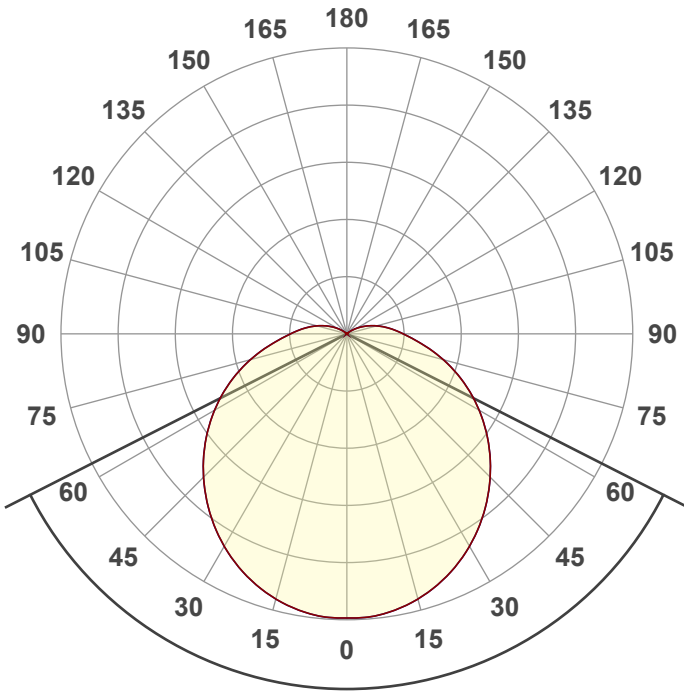

Tracking number: [VT240919-002643](#)

Product name:
273672-4000K

Item number:
273672-4000K

Date and time:
19-9-2024 10:00:33

Description:

LED BULKHEAD OVAAL 8W

Beam angle **126,1°**



CIE 1931
x: 0,381
y: 0,377

Spectra

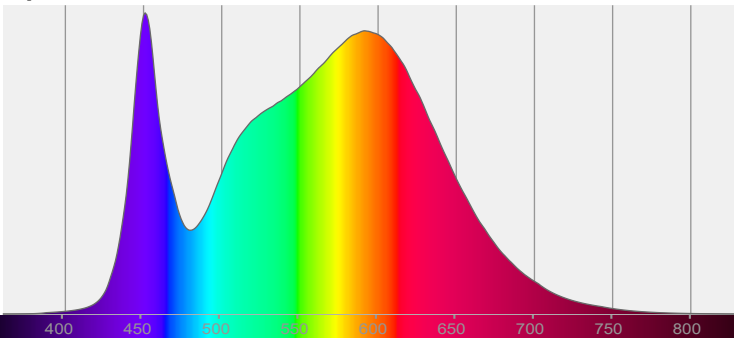

Power

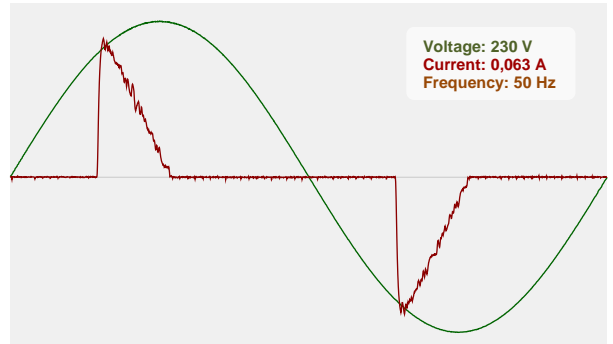

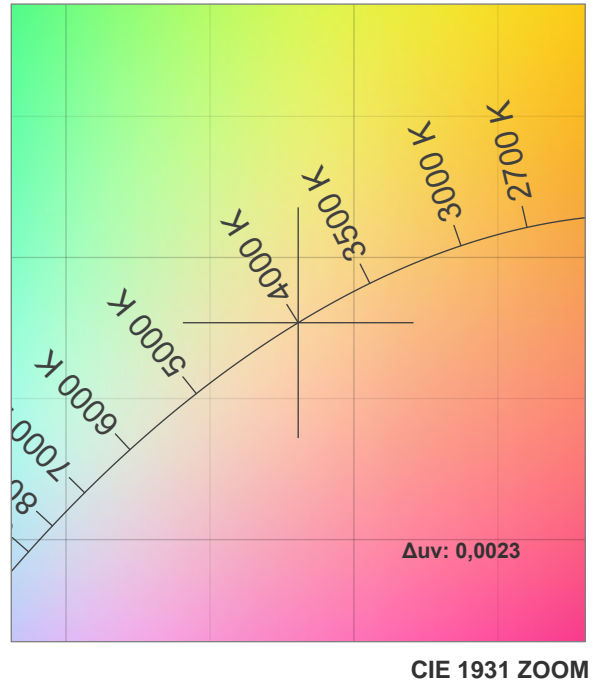
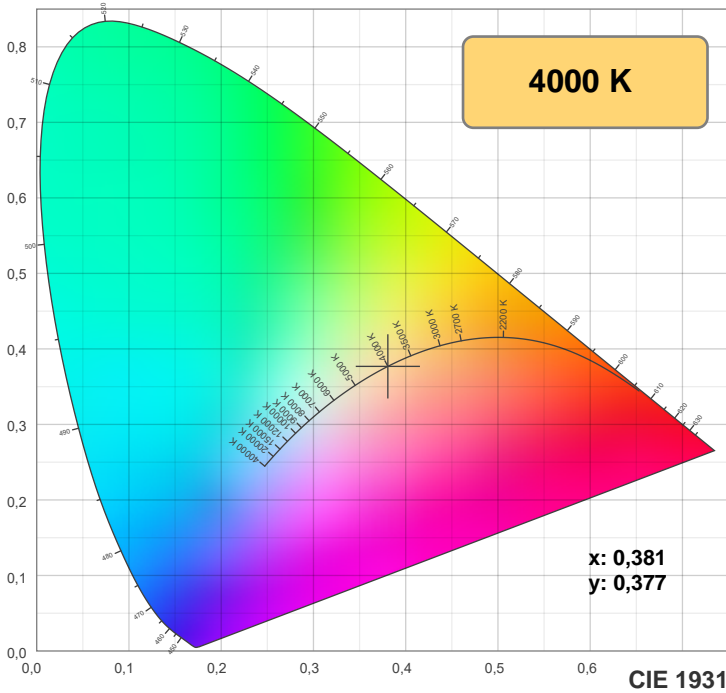

TM-30: 83,9

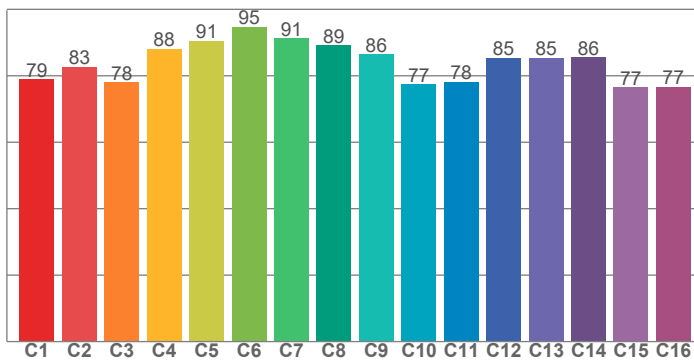

CRI: 82,3 (R1-R8)

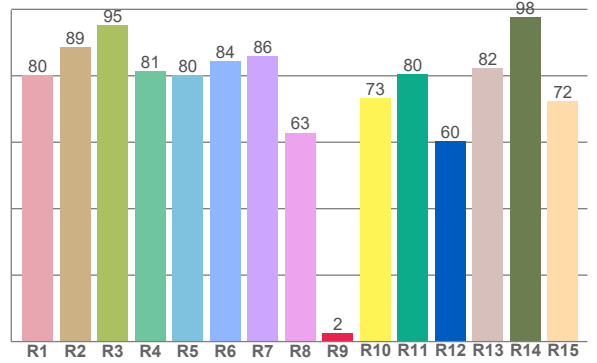

CQS: 82,0

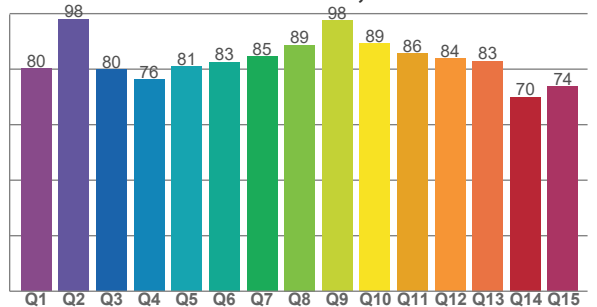

CRI R values, only R1-R8 are used to calculate final CRI value

R1	R2	R3	R4	R5	R6	R7	R8	R9	R10	R11	R12	R13	R14	R15
80,1	88,6	95,2	81,4	80,2	84,4	85,9	62,9	2,5	73,3	80,5	60,4	82,3	97,6	72,4

TM30 C values, 16 binned values out of total of 99 C values

C1	C2	C3	C4	C5	C6	C7	C8	C9	C10	C11	C12	C13	C14	C15	C16
79,0	82,7	78,1	88,2	90,5	94,7	91,3	89,1	86,4	77,4	78,2	85,4	85,4	85,6	76,6	76,7

CQS Q values

Q1	Q2	Q3	Q4	Q5	Q6	Q7	Q8	Q9	Q10	Q11	Q12	Q13	Q14	Q15
80,2	98,0	79,9	76,3	80,9	82,6	84,6	88,6	97,5	89,2	85,7	83,9	82,9	69,9	73,8

Color parameters

Color temperature	Color rendering index	Red component	Color fidelity	Color gamut	Color quality scale	Color coordinate cie 1931	Color coordinate cie 1931	Color coordinate	Color coordinate	Color deviation from black body
CCT	CRI	CRI R9	TM30 Rf	TM30 Rg	CQS	x	y	u	v	Δuv
4000 K	82,3	2,5	83,9	94,6	82,0	0,381	0,377	0,225	0,334	0,0023

Rf 83,9
Fidelity index Rf

Rg 94,6
Gamut index Rg

Hue Bin	R _f	Shifts (%)	
		Chroma	Hue
1	79	-13%	-1%
2	83	-8%	6%
3	78	-4%	11%
4	88	0%	7%
5	91	0%	4%
6	95	1%	-2%
7	91	-4%	-3%
8	89	-7%	0%
9	86	-7%	6%
10	77	-7%	12%
11	78	3%	14%
12	85	6%	5%
13	85	8%	-8%
14	86	3%	-8%
15	77	-2%	-17%
16	77	-7%	-13%

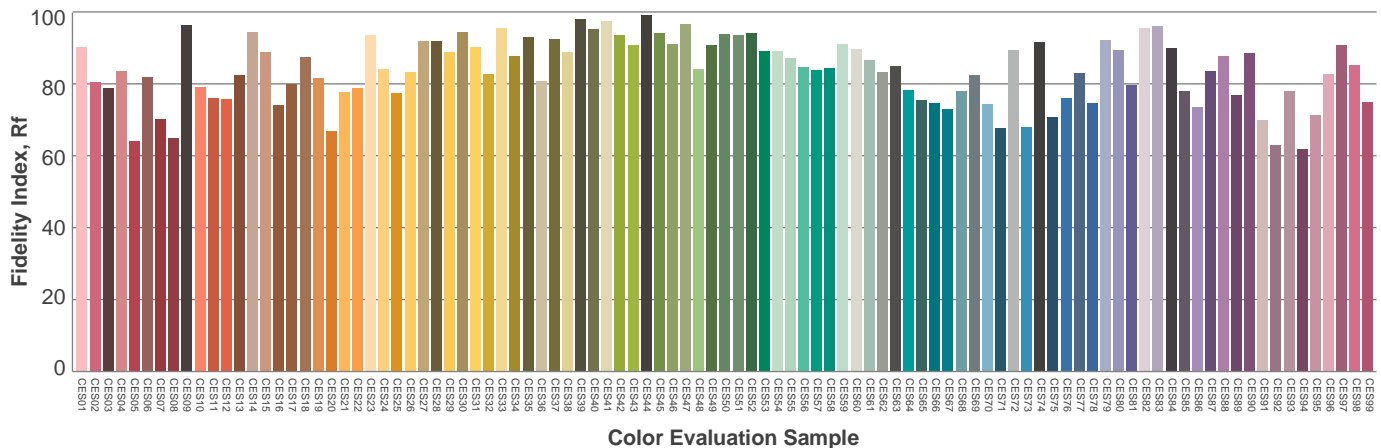
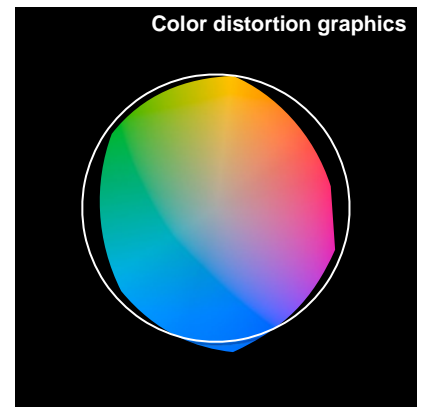
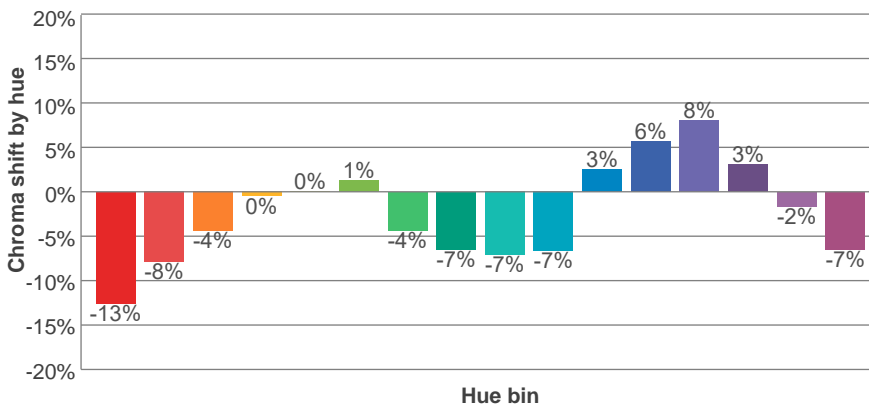
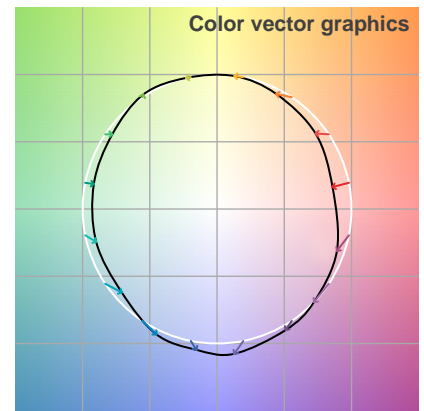
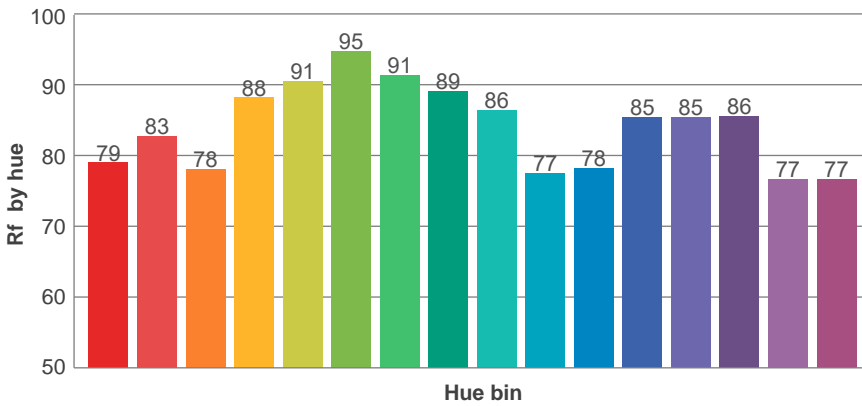
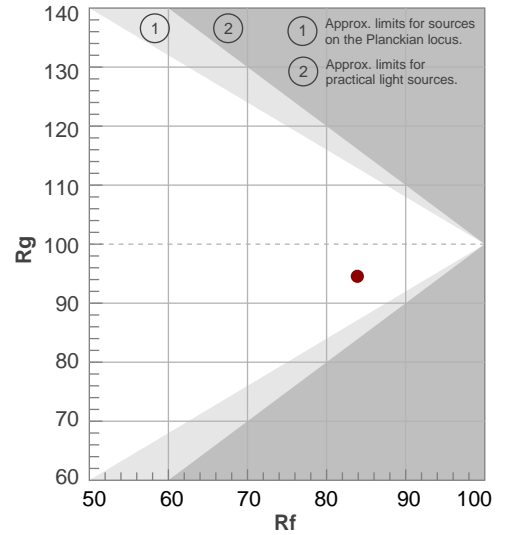

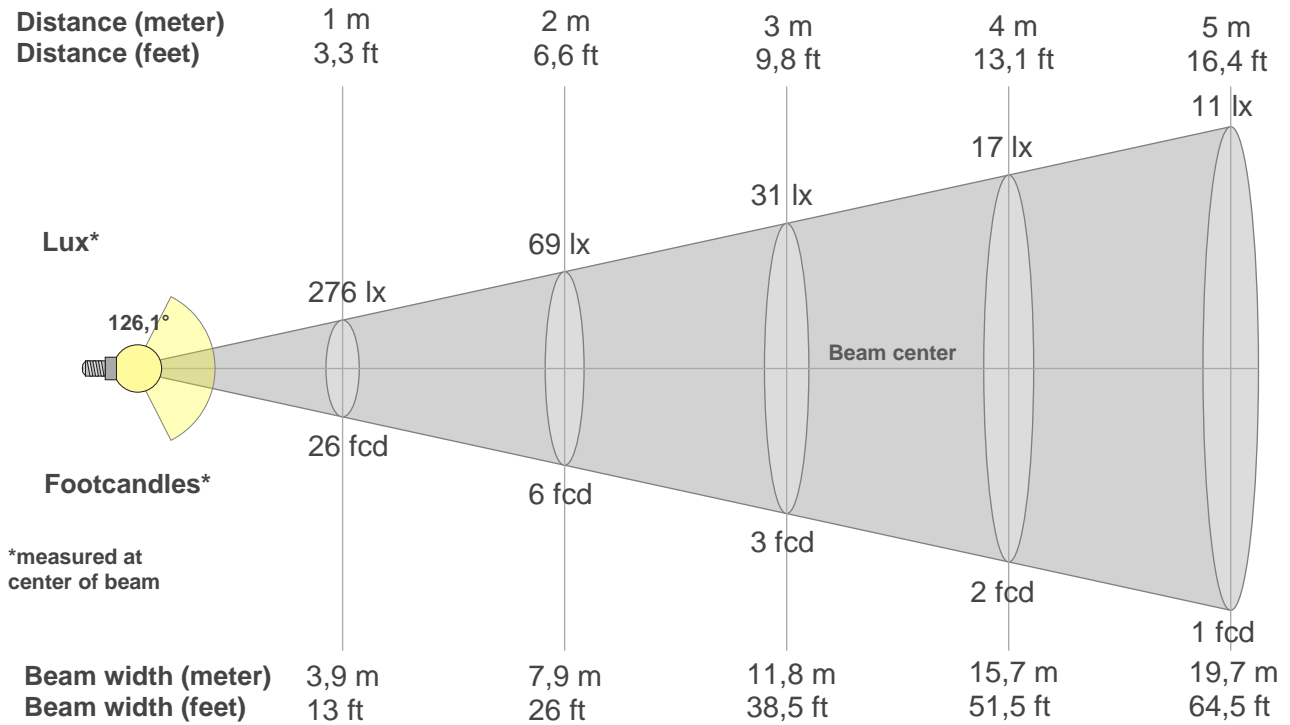

Beam intensities from 1-20m

1m	2m	3m	4m	5m	6m	7m	8m	9m	10m	11m	12m	13m	14m	15m	16m	17m	18m	19m	20m
3,3ft	6,6ft	9,8ft	13,1ft	16,4ft	19,7ft	23ft	26,2ft	29,5ft	32,8ft	36,1ft	39,4ft	42,7ft	45,9ft	49,2ft	52,5ft	55,8ft	59,1ft	62,3ft	65,6ft
276lx	69lx	31lx	17lx	11lx	8lx	6lx	4lx	3lx	3lx	2lx	2lx	2lx	1lx	1lx	1lx	1lx	1lx	1lx	1lx
25,6fcd	6,4fcd	2,8fcd	1,6fcd	1fcd	0,7fcd	0,5fcd	0,4fcd	0,3fcd	0,3fcd	0,2fcd	0,2fcd	0,2fcd	0,1fcd	0,1fcd	0,1fcd	0,1fcd	0,1fcd	0,1fcd	0,1fcd

Intensities in 0° c-plane

0°	9°	18°	27°	36°	45°	54°	63°	72°	81°	90°	99°	108°	117°	126°	135°	144°	153°	162°	171°
276	273	262	245	222	196	168	138	107	78	55	39	26	14	5	1	0	0	0	0
100%	99%	95%	89%	81%	71%	61%	50%	39%	28%	20%	14%	9%	5%	2%	0%	0%	0%	0%	0%

Intensities in 90° c-plane

0°	9°	18°	27°	36°	45°	54°	63°	72°	81°	90°	99°	108°	117°	126°	135°	144°	153°	162°	171°
276	273	262	245	222	196	168	138	107	78	55	39	26	14	5	1	0	0	0	0
100%	99%	95%	89%	81%	71%	61%	50%	39%	28%	20%	14%	9%	5%	2%	0%	0%	0%	0%	0%

Intensities in 180° c-plane

0°	9°	18°	27°	36°	45°	54°	63°	72°	81°	90°	99°	108°	117°	126°	135°	144°	153°	162°	171°
276	273	262	245	222	196	168	138	107	78	55	39	26	14	5	1	0	0	0	0
100%	99%	95%	89%	81%	71%	61%	50%	39%	28%	20%	14%	9%	5%	2%	0%	0%	0%	0%	0%

Intensities in 270° c-plane

0°	9°	18°	27°	36°	45°	54°	63°	72°	81°	90°	99°	108°	117°	126°	135°	144°	153°	162°	171°
276	273	262	245	222	196	168	138	107	78	55	39	26	14	5	1	0	0	0	0
100%	99%	95%	89%	81%	71%	61%	50%	39%	28%	20%	14%	9%	5%	2%	0%	0%	0%	0%	0%

Beam angle 50%	Field angle 10%	Cutoff angle 2,5%	Intensity ratio in 120° cone	Intensity ratio in 90° cone
126,1°	213,3°	247°	61,6%	40,6%

iso-candela diagram

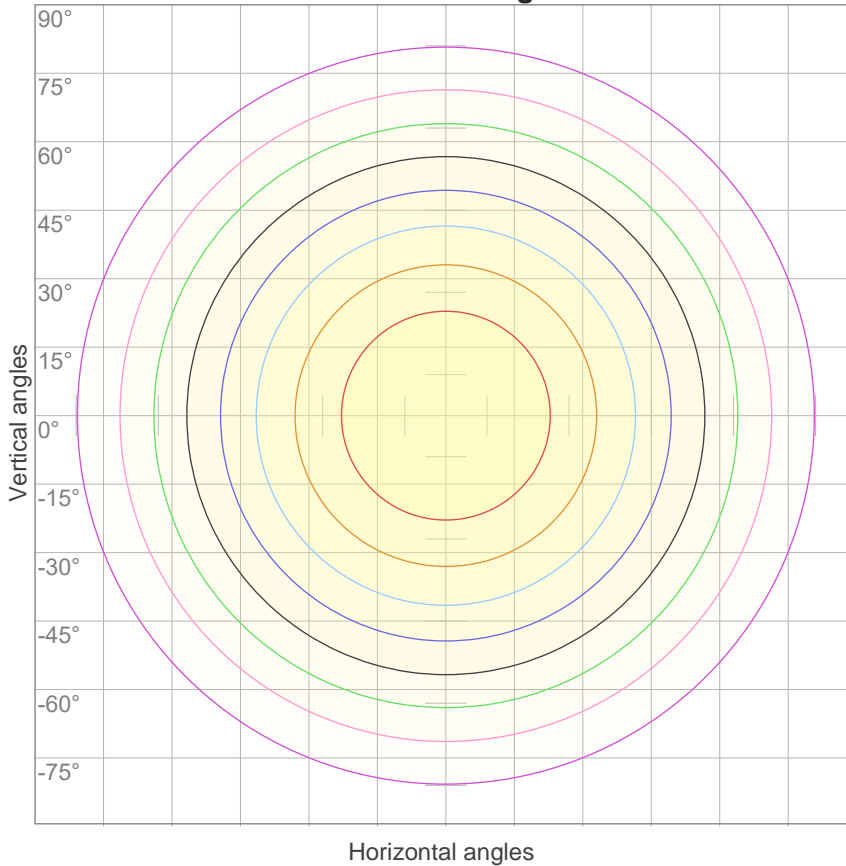

10%	28 cd
20%	55 cd
30%	83 cd
40%	110 cd
50%	138 cd
60%	165 cd
70%	193 cd
80%	220 cd
90%	248 cd

Conditions:

Number of c-planes: 44

Candela at center: 276 cd

iso-lux diagram

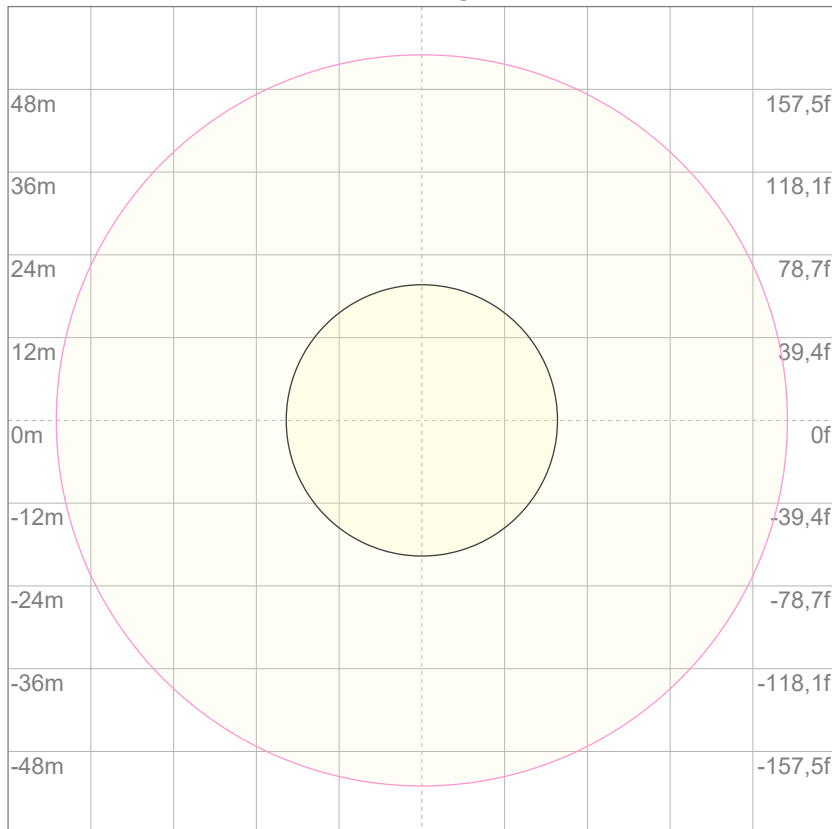

3%	82,7m lx
5%	0,138 lx
10%	0,276 lx
30%	0,827 lx
50%	1,38 lx

Conditions:

Number of c-planes: 44

Lux at center: 2,76 lx

Lux distribution on a surface when lamp is mounted at 10 meters from the surface.

Glare evaluation according to UGR

p Ceiling		70	70	50	50	30	70	70	50	50	30
p Walls		50	30	50	30	30	50	30	50	30	30
p Floor		20	20	20	20	20	20	20	20	20	20
Room size X Y		Viewing direction at right angles to lamp axis					Viewing direction parallel to lamp axis				
2H	2H	21,4	22,6	21,8	23,1	23,5	21,4	22,6	21,8	23,1	23,5
	3H	23,3	24,5	23,8	25,0	25,4	23,3	24,5	23,8	25,0	25,4
	4H	24,2	25,4	24,8	25,9	26,3	24,2	25,4	24,8	25,9	26,3
	6H	25,2	26,2	25,6	26,7	27,3	25,2	26,2	25,6	26,7	27,3
	8H	25,6	26,7	26,1	27,1	27,7	25,6	26,7	26,1	27,1	27,7
	12H	26,0	27,1	26,5	27,5	28,1	26,0	27,1	26,5	27,5	28,1
4H	2H	22,1	23,3	22,7	23,8	24,2	22,1	23,3	22,7	23,8	24,2
	3H	24,3	25,4	24,8	25,8	26,4	24,3	25,4	24,8	25,8	26,4
	4H	25,3	26,4	25,9	26,8	27,5	25,3	26,4	25,9	26,8	27,5
	6H	26,4	27,3	27,0	27,8	28,4	26,4	27,3	27,0	27,8	28,4
	8H	26,9	27,7	27,5	28,3	28,8	26,9	27,7	27,5	28,3	28,8
	12H	27,4	28,1	28,0	28,7	29,3	27,4	28,1	28,0	28,7	29,3
8H	4H	25,8	26,6	26,4	27,1	27,7	25,8	26,6	26,4	27,1	27,7
	6H	27,1	27,7	27,7	28,3	29,0	27,1	27,7	27,7	28,3	29,0
	8H	27,7	28,3	28,4	29,0	29,8	27,7	28,3	28,4	29,0	29,8
	12H	28,4	28,9	29,1	29,6	30,3	28,4	28,9	29,1	29,6	30,3
12H	4H	25,8	26,5	26,4	27,1	27,7	25,8	26,5	26,4	27,1	27,7
	6H	27,2	27,8	27,9	28,5	29,3	27,2	27,8	27,9	28,5	29,3
	8H	28,0	28,5	28,7	29,1	29,9	28,0	28,5	28,7	29,1	29,9
Variation of the observer position for the luminaire distance S											
S = 1.0H		0,1 / -0,1					0,1 / -0,1				
S = 1.5H		0,1 / -0,1					0,1 / -0,1				
S = 2.0H		0,2 / -0,2					0,2 / -0,2				
CIE 117-1995. Corrected glare indices referring to 1065 lm total luminous flux											

Coefficients of Utilization

Ceiling reflectance	80				70				50			30			10			0			
Wall reflectance	70	50	30	10	70	50	30	10	50	30	10	50	30	10	50	30	10	0			
Floor reflectance	20	20	20	20	20	20	20	20	20	20	20	20	20	20	20	20	20	20	20	20	0
RCR	(RCR: Room Cavity Ratio)																				
	Room Values are expressed as percentage of Lumens delivered to the task surface																				
0	117	117	117	117	113	113	113	113	106	106	106	99	99	99	93	93	93	90			
1	104	98	93	88	100	95	90	86	89	85	81	83	80	77	78	75	73	70			
2	93	84	76	70	90	81	74	68	76	70	65	71	66	62	67	63	59	56			
3	85	73	64	57	81	71	62	56	66	59	53	62	56	51	58	53	49	46			
4	77	64	55	48	74	62	53	47	58	51	45	55	48	43	52	46	42	39			
5	71	57	48	40	68	55	46	40	52	44	38	49	42	37	46	40	36	33			
6	65	51	42	35	63	50	41	34	47	39	33	44	37	32	42	36	31	29			
7	60	46	37	31	58	45	36	30	42	35	29	40	33	28	38	32	28	25			
8	56	42	33	27	54	41	33	27	39	31	26	37	30	25	35	29	25	23			
9	52	39	30	24	50	38	30	24	36	28	23	34	27	23	32	26	22	20			
10	49	35	27	22	47	35	27	22	33	26	21	31	25	21	30	24	20	18			

LAMPS (number of lamps)

Luminaire budgetary diagram

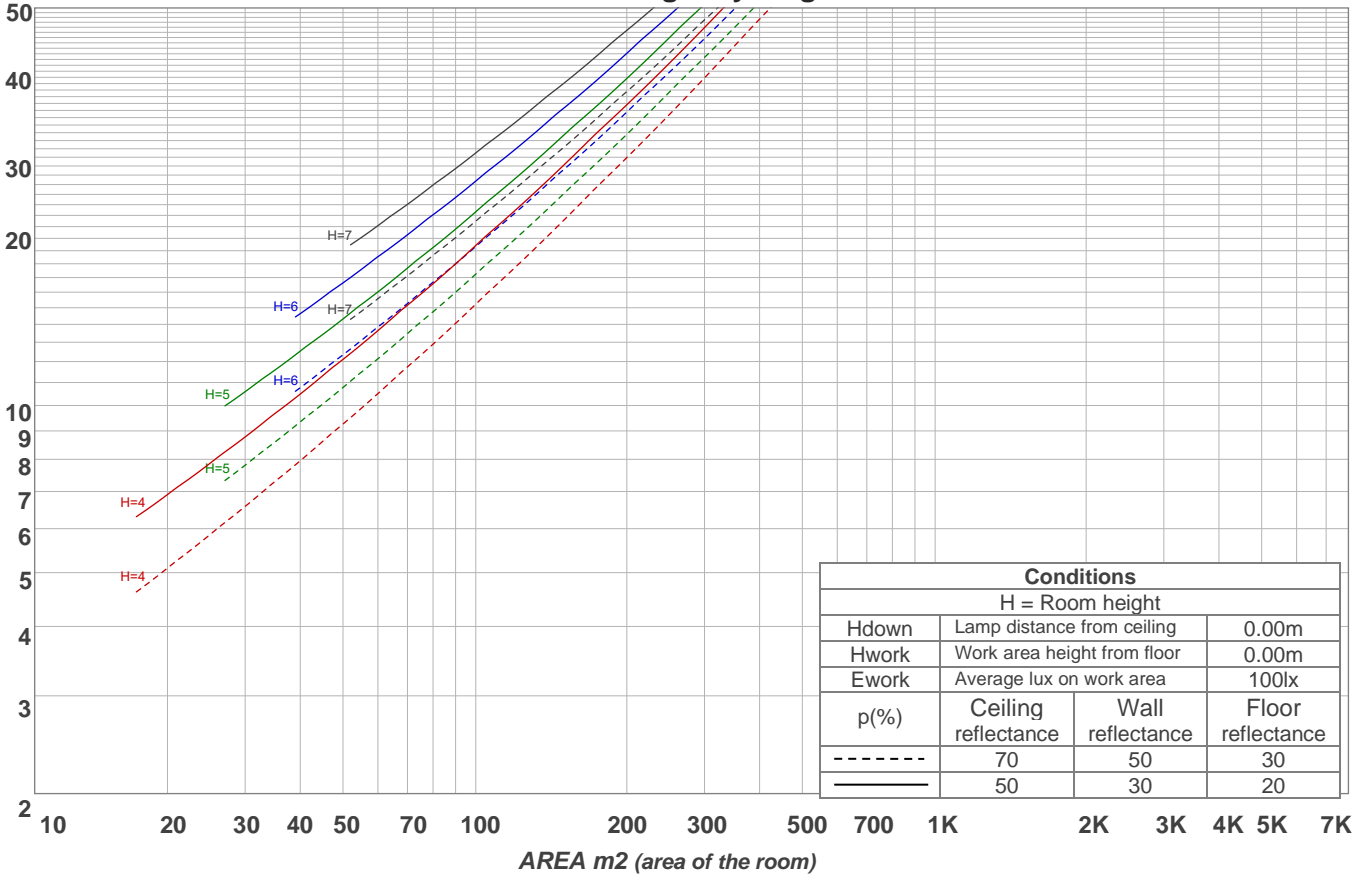

Zonal Lumen Summary

0°-10°	10°-20°	20°-30°	30°-40°	40°-50°	50°-60°	60°-70°	70°-80°	80°-90°
{LUM0-10}	75,1 lm	115 lm	141 lm	152 lm	147 lm	130 lm	102 lm	72,6 lm
90°-100°	100°-110°	110°-120°	120°-130°	130°-140°	140°-150°	150°-160°	160°-170°	170°-180°
50,0 lm	31,8 lm	16,3 lm	5,35 lm	0,703 lm	0,117 lm	0,082 lm	0,046 lm	0,016 lm

LCS table

BUG rating:	B1 U3 G1	
Forward light	Lumens	Lumens %
Low(0-30):	108	10,1%
Medium(30-60):	220	20,6%
High(60-80):	116,1	10,9%
Very high(80-90):	36,4	3,4%
Back light		
Low(0-30):	108	10,1%
Medium(30-60):	220	20,6%
High(60-80):	116,1	10,9%
Very high(80-90):	36,4	3,4%
Uplight		
Low(90-100):	50	4,7%
High(100-180):	54,5	5,1%

LCS graph

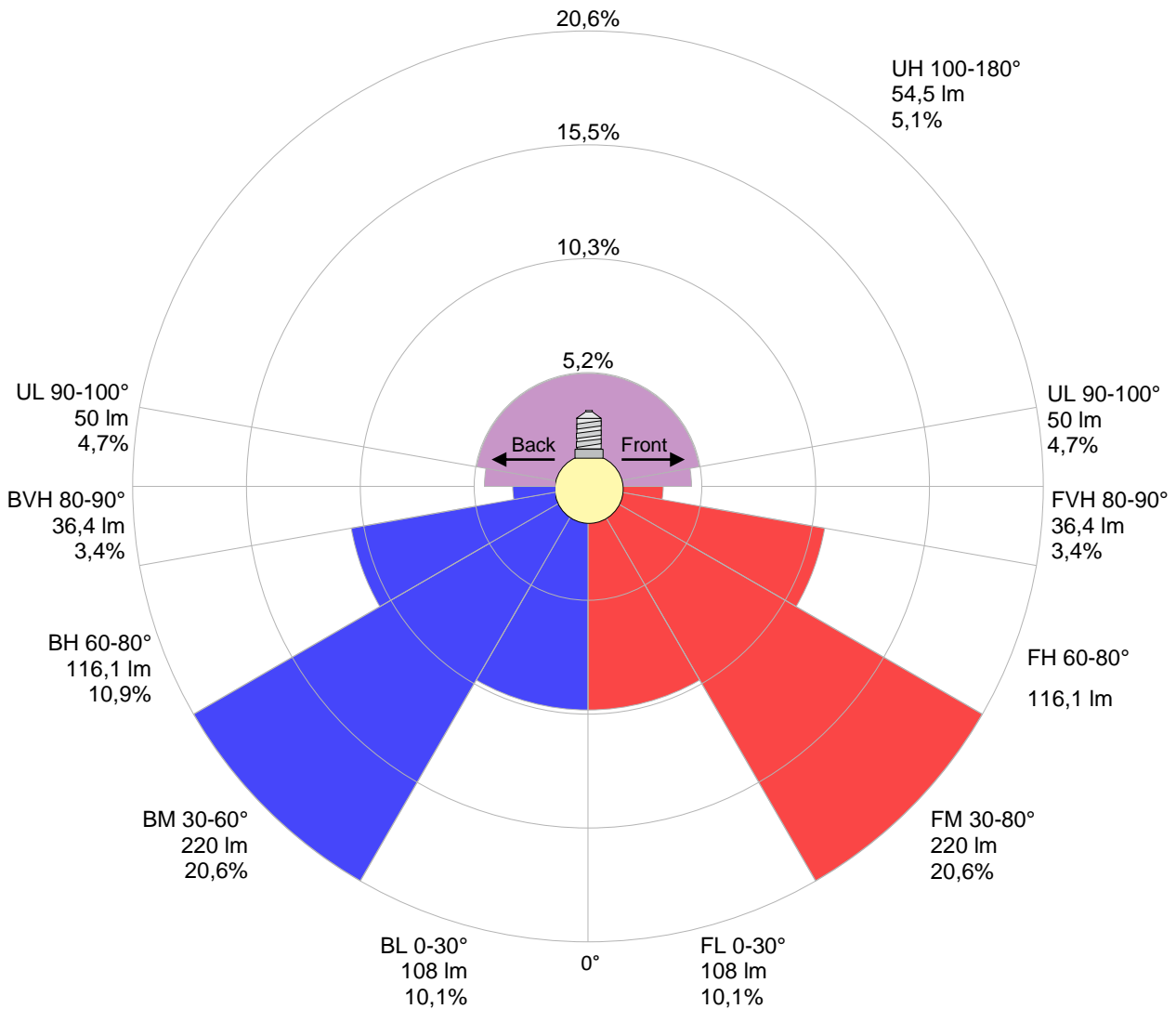

Warmup curve

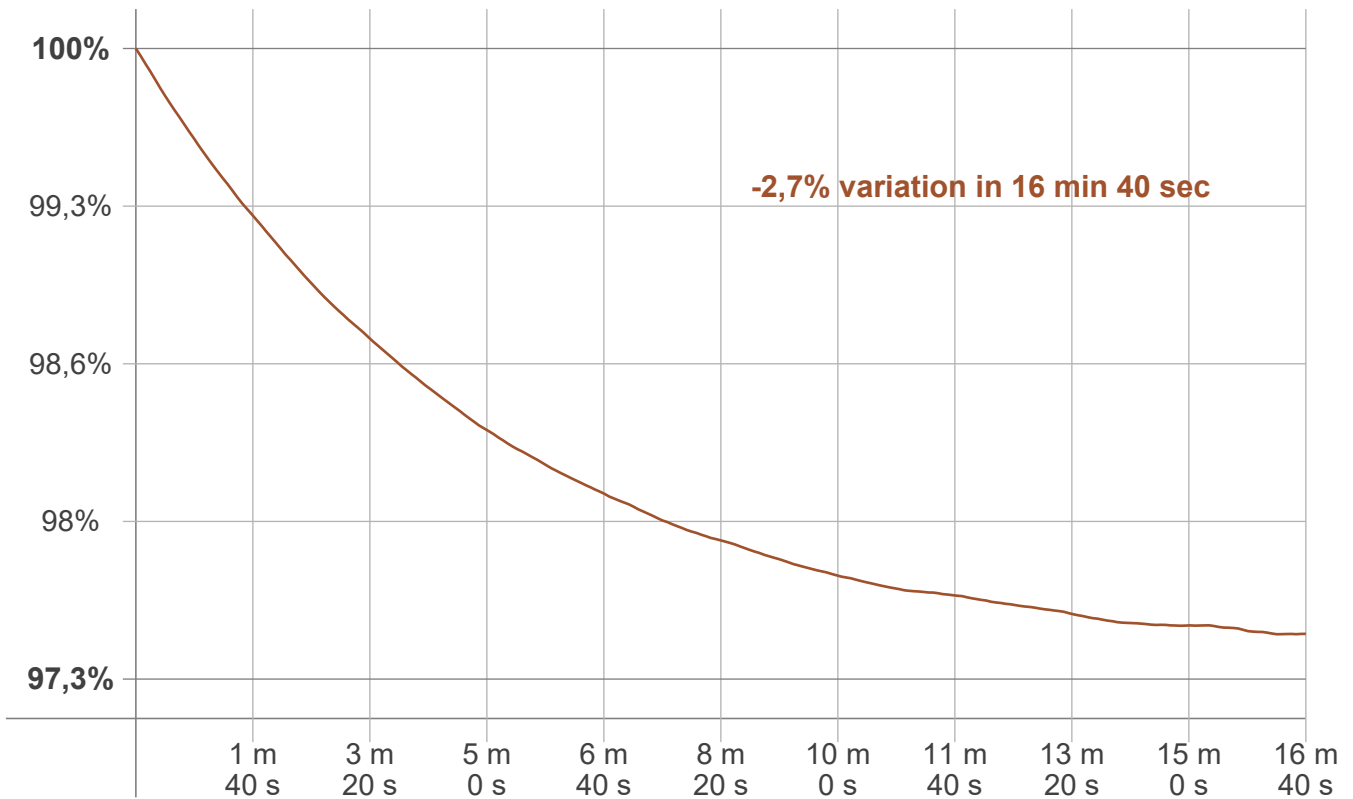

Warmup result

Warmup time:	Lamp stabilized in 16 min 40 sec
Warmup variation	-2,7%

Warmup conditions

Stable period:	15 min
Stable change max:	2,0%
Minimum time:	15 min

Color temperature change

CCT start	CCT change	CCT end
3977 K	+23 K	4000 K

Output change

Output start	Output change	Output end
1095 lm	-29 lm	1065 lm

Flicker curve (complete sampled flicker signal)



Flicker frame (frame of one flicker period)

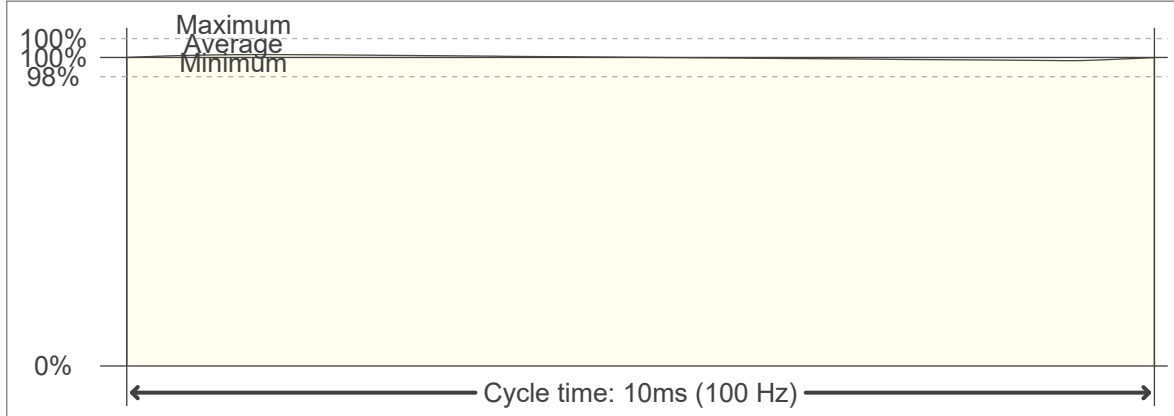

Flicker FFT (frequency scope of flicker curve)



Flicker results:

Flicker frequency:		100 Hz	
Flicker index:	0	JA8/10 40Hz	0,03 %
Flicker percentage:	1,03 %	JA8/10 90Hz	0,04 %
SVM: (Visual flicker)	0,03	JA8/10 200Hz	0,87 %
PstLM	0,03	JA8/10 400Hz	1,02 %
Mp	0,01	JA8/10 1000Hz	1,02 %

Flicker conditions:

Sample rate:	20000 samples/second
--------------	----------------------